

ITEM	PART NO	DESCRIPTION	MATERIAL	PLATING	
①	PCX6.0AA-B-R1	BARREL	BeCu	Au	
②	PCX6.0AA-P-R1	Plunger	BeCu	Au	
③	PCX6.0AA-S	Spring	SWP	Au	
MARK	DESCRIPTION OF REVISION			DATE	NAME
△	Barrel Side hole size and position changed.			04.Jan.12	S.Izumi
△	Plunger diameter was changed to 0.58 from 0.6mm.			04.Feb.16	S.Izumi

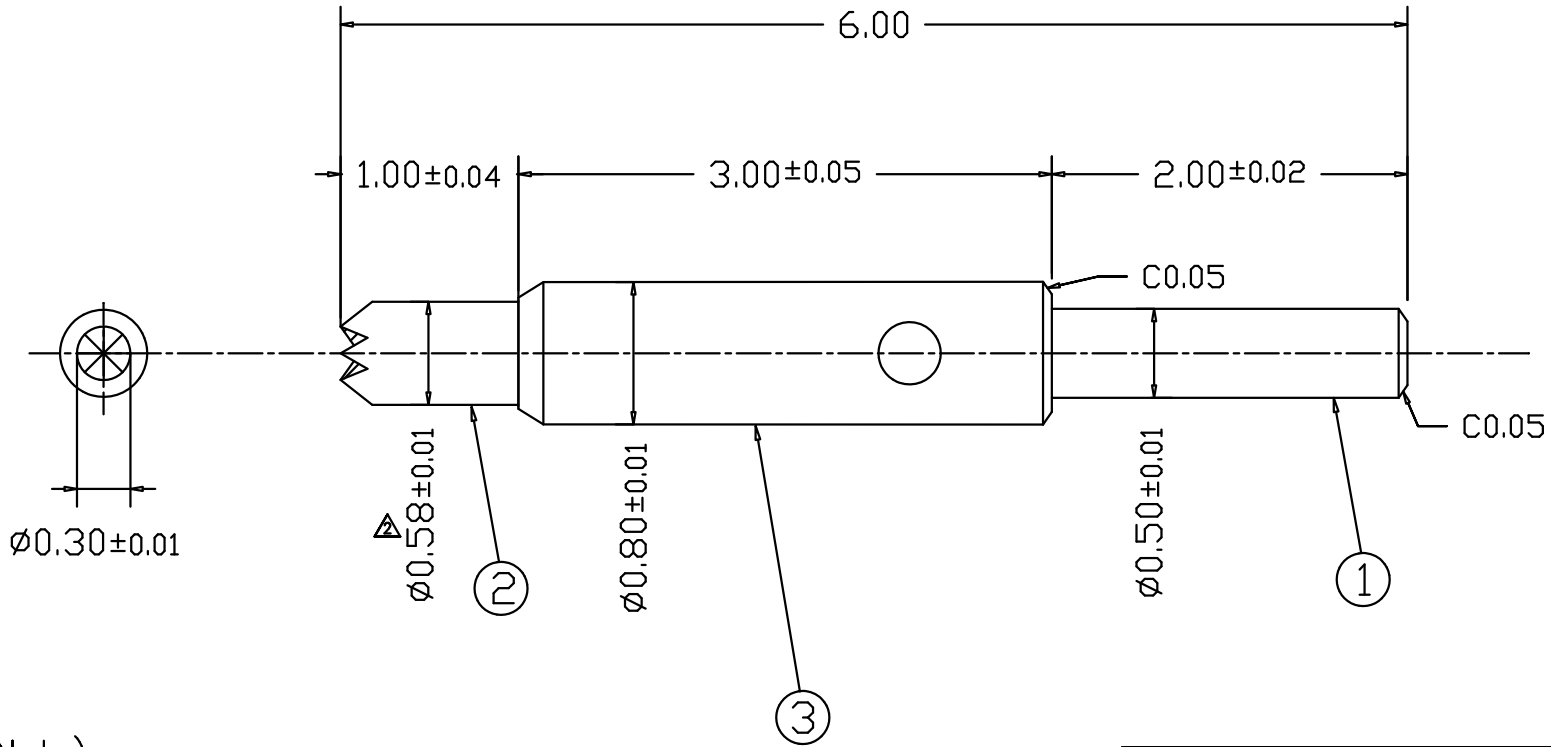

(Note)

1. Spring Force : 35g. \pm 6g (@ 0.5mm , working travel)
2. Max Travel : 0.8mm (47gf.)

AK
BS
QC
PRC
FCT
NGM

DESIGNED	TITLE		
CHECKED	Assembly Drawing		
APPROVED	SIZE	DWG NO.	△
S.Izumi	A4	PCX6.0AA	
DRAWN	SCALE	Link-MicRo' Co.,Ltd..	
2003.09.25			